

## TABLE OF CONTENTS

	PAGES
<b>SECTION 1: 2026 USTS OFFICERS, OFFICIALS, COMMITTEES.....</b>	<b>1</b>
<b>SECTION 2: USTS RULES &amp; REGULATIONS.....</b>	<b>2 - 4</b>
<b>SECTION 3: USTS GENERAL RACING RULES.....</b>	<b>5 - 12</b>
<b>SECTION 4: USTS SAFETY RULES &amp; REGULATIONS.....</b>	<b>13 - 18</b>
<b>SECTION 5: USTS TECH RULES.....</b>	<b>19 - 33</b>



## **USTS OFFICERS & DIRECTORS-2026**

**President**  
**Vice President**  
**Secretary**  
**Treasurer**  
**Directors**

Pete Nydahl  
Mike Thirlby  
Andy Kirts  
**Paul Bosnich III**  
Ben Thompson, Jerry Davids Sr., **Gary Merkel**

## **USTS OFFICIALS -2026**

**Race Director:** **Ben Thompson, Jerry Davids Sr., Kurtis Nydahl**  
**Referee:** Robert Trolan Jr  
**Assistant Referee:** Paul Bosnich III  
**Risk Manager:** Andy Kirts  
**Assistant Risk Manager:** **Pete Nydahl**  
**Chief Scorer:** Denise Eldredge  
**Timer:** Kelly Nydahl  
**Inspector:** Rex Hall, Jerry David Sr., Mike Wienandt  
**Announcer:** Jackson Lightcap

## **USTS COMMITTEES - 2026**

**Show Money Policy** - Mike Thirlby  
**Record Course Committee** - Paul Bosnich III, Pete Nydahl  
**700cc Runabout Committee** - Mike Thirlby, Jim Wright  
**Tech Committee** - Mike Schmidt, Rex Hall, Jerry Davids Sr.  
**Safety Committee** - Ben Thompson, Andy Kirts, Gary Merkel  
**Capsule Committee** - Andy Kirts



## RULES AND REGULATIONS

1. The US Title Series Association (“US Title Series” or “USTS”) shall be regulated by the US Title Series’ Rules and Regulations, the US Title Series’ By-Laws, and the majority vote of the USTS Board of Directors.
2. The USTS Board of Directors, in its sole discretion and at any time, may request a driver to obtain a medical release from a driver’s personal physician acknowledging that the driver is fit to participate in any USTS races that the driver wishes to participate in, free of any medical concerns.
3. The annual Race Class High Point Champion will be determined by the total number of points received for the year by each driver. The US Title Series will use the US Title Series’ Point System to award points. The driver with the most accumulated points for the year will be crowned the Class High Point Champion.
4. Race classes are comprised of 125cc, 250cc, 350cc, 500cc, 1100cc Hydro and Runabout, KPro Hydro, KPro Runabout, 175 Hydro, and 700 Runabout.
5. Special event race classes do not run for prize, or show money.
6. 700 & 1100 Runabout will only run 2 heats, except at Nationals. KPRO will run 2 heats each day (Saturday & Sunday) except at Nationals. All remaining classes will run a 3-heat format.
7. Step-ups may be allowed to fill all classes at the discretion of the USTS Board of Directors.
8. Special event classes shall be determined on a per-race venue basis. These special classes will be run at the end of the day or as determined by the race director and chief scorer.
9. To participate in a US Title Series race, the driver and or deck rider must be a Racing Member of the US Title Series.
10. Every race boat competing in a US Title Series Race Event, to race and receive show money, must have the USTS emblem permanently and prominently affixed to both sides of the registered race boat.
11. All participants and pit crew will adhere to a dress code. Pit crew members operating in the water shall have matching shirts. T-shirts are acceptable, and must have racing identification – either team identification or US Title Series. Crew members must also have appropriate pants and/or shorts.
12. Everyone in the hot pit area must wear a wristband. These must be worn on the wrists, and cannot be attached to hats or other articles of clothing. The hot pit is defined as the area fenced around the race trailers and race boats.
13. The US Title Series Board of Directors has the authority to take disciplinary action and/or levy fines against any participant, would-be participant, or any crew member who does not meet the standards of professionalism and sportsmanship required for participation in the US Title Series.
14. Fire extinguishers are required to be mounted either inside or outside of each trailer in an easily accessible area, in proximity to the fueling area.
15. Registration time will be established by the race director and chief scorer. All race entries must be received by the chief scorer before the close of registration. If a driver is unable to be present at the scheduled registration, the driver must either pre-register in writing or by e-mail. In an emergency, another person can register for the driver with the chief scorer; a telephone call by the driver to the chief scorer will be accepted as pre-registration. At the driver’s meeting, the driver will complete the registration with the chief scorer.

16. The time for the driver's meeting will be determined by the race director, referee, and chief scorer and will be posted on the race sanction. It will begin at least one-half hour before the start of the racing for that day.
17. All race courses shall consist of an oval or tri-oval, no more than one mile in length.
18. Any course buoy (turn buoy or outside marker) destroyed, will cost the driver destroying the buoy \$75.00.00 payable to the US Title Series. . The above fine shall be \$100 if the buoy is destroyed and the anchor is lost.
19. If more than the maximum number of entries are registered for a class that can safely be run on the course as determined by the referee, additional heats will be run in place of the first two heats. The final class heat will consist of the highest-scoring boats, not exceeding the maximum number that can be safely run on the course. The final race position for each racer will be determined by summing points from all heats.
20. Each heat will end when the first legal boat crosses the finish line. All other boats will finish their current lap and be scored as finished. Boats running laps down will be scored as if they finished those laps.
21. Show money shall be a minimum of \$5,000.00 per race, per the discretion of a majority vote of the USTS Board of Directors.
22. USTS show money policy:
  - a. USTS will calculate one-way driving miles from the home of each driver to the race site using the website [http://maps.randomcally.com/mileage\\_calculator?loc\[\]=&loc\[\]=](http://maps.randomcally.com/mileage_calculator?loc[]=&loc[]=)
  - b. Chief Scorer will provide a list of the number of heat starts of each driver, regardless legal or jump.
  - c. Step-ups will not count towards starts.
  - d. Multiply previously determined miles by number of starts to get total points.
  - e. Divide show money by the total points of all drivers to get a per-point value paid to each driver or owner.
  - f. Pay the driver or owner as directed on the registration form.
  - g. Driver must sign USTS mileage reimbursement form.
23. If there is prize money in addition to show money, the policy will be as follows: All entries will be counted after registration is closed on Saturday. At this time we will determine how many total boats are entered. All boats entered will be divided into the total prize money to determine how much each boat is worth. Class will be paid on the number of boats entered times the value of each boat. The higher the number of entries in the class, the more prize money there will be for that class. Prize money will be paid by the following schedule:

6 or Less Boats	7 to 8 Boats	9 to 10 Boats	11to12 Boats
<i>3Pay</i>	<i>4Pay</i>	<i>5Pay</i>	<i>6Pay</i>
50%	40%	30%	30%
30%	30%	25%	24%
20%	20%	20%	18%
	10%	15%	12%
		10%	9%
			7%
13 to14 Boats	15 to16 Boats	17to18 Boats	19 & Over Boats
<i>7Pay</i>	<i>8Pay</i>	<i>9Pay</i>	<i>10Pay</i>
25%	25%	20%	20%
20%	20%	17%	19%
17%	15%	15%	15%
14%	12%	12%	11%
10%	10%	10%	10%
8%	8%	8%	7%
6%	6%	7%	6%
	4%	6%	5%
		5%	4%
			3%

24. If the scheduled race venue is run under adverse conditions, as determined by the referee, then, in order to put on an exhibition for the sponsor, all legal starters will only receive 100 points toward the annual Class High Point Champion Award. Show money will be paid per the Show Money Policy.
25. In case of a weather blow-out during a multiple-day race schedule event, two completed class heats will constitute a race. If only one class heat is completed, at least one more heat will be run on the following day. All class heats completed on the last scheduled race day will constitute a race.

26. The decision to cancel a race, due to inclement weather, will be made by the referee, race director, and the sponsor. Racing will be started no later than 5:00 p.m.
27. Sponsors will be advised to purchase an inclement weather policy. In the event of cancellation, the inclement weather policy will cover the officials' expenses, equipment expenses, and payout per the Show Money Policy to the drivers.
28. Bids for US Title Series race events shall be presented to the Board of Directors on or before the first of February for planning the current year race schedule. Previous US Title Series sponsors shall have the right of first refusal based on the prior year's event dates.



## General Racing Rules

1. **SANCTIONS:** To obtain a sanction, or instruction on how to conduct races, contact the US Title Series (USTS) office. Applications for sanctions must be received by the USTS office no less than 30 days before the day of the race. Sanctions will only be granted to affiliated clubs in good standing. Applications for championships or other national events should be in the USTS office by the annual meeting.
  - a. Sanction fees:
    - 1) USTS race - \$400.00
    - 2) Championship races (Nationals) \$500.00. Championship races are defined as awarding additional points to the participants. National Championship races will be awarded 1 ½ times the normal points. (e.g. 1<sup>st</sup> - 400 = 600 points)
    - 3) Record Runs - \$400.00
  - b. Sanction applications will not be honored where races conflict with championship events, or within a 500-mile radius of a previously granted event. Speed trials or record runs will not be permitted without a sanction being granted by the USTS.
  - c. A USTS-sanctioned event shall consist of three – four-lap heats of racing per class unless otherwise stated on the sanction. Probationary classes shall run two heats.
2. **RACE MANAGEMENT:** The management of races and all boats taking part therein shall be under the strict and exclusive control of the referee. It shall be the duty of that referee to see that all provisions of the sanction application are adhered to by the host club. All matters shall be subject to the approval and control of the referee, and all questions and disputes, that may arise, shall be decided by the referee and his/her decision shall be final, except when an appeal may be made to the USTS Board of Directors (BOD). Any such appeal to the BOD must be in writing and accompanied by a fee of \$100.00. The \$100.00 fee is refundable if the BOD rules in favor of the driver. Race committees are to be appointed to assist the referee in carrying out his/her duties. The host club shall appoint all necessary personnel to conduct the races. To be an official at all USTS events, scorers, referees, timekeepers, inspectors, etc. must be a member of the USTS before the time of the appointment.
3. **COMPENSATION OF RACE OFFICIALS:** Sponsoring organizations are responsible for the expenses of the race officials.
4. **RACE OFFICIALS AND DUTIES:** No official, regardless of his/her duty, will be permitted to officiate an event under the influence of alcoholic beverages, including beer and hallucinogenic drugs, and any other substance that would impair their mental or physical abilities. The referee is responsible for the enforcement of the above rules without exception. The referee, in enforcing the above, shall dismiss the guilty official and may, if he/she sees fit, file charges against said official as outlined under "Discipline" found under PENALTIES FOR DISQUALIFICATIONS.
  - a. **Referee:** The referee shall be a member of the USTS in good standing and appointed by the BOD. It shall be the duty of the referee to represent the association to ensure that all rules are strictly enforced and to work with the local officials to stage a trouble-free race. He/she shall see to it that all provisions of the sanction and race contract are fulfilled and shall have the authority to appoint assistants. The referee must ensure that the appropriate marine permits (if required), insurance certificate, and sanction papers are on file, and the medical response team i.e.: (EMT, paramedics rescue unit LSV...) are on the scene before starting the race. Pickup boats and rescue crews are stationed in their proper places and all safety precautions are taken to protect drivers and spectators. He/she shall be in complete charge of all association members, drivers, and officials, but not the tech inspectors at championship races. The referee will have jurisdiction at the race site from ½ hour after sunrise on the first scheduled sanction day, to 1 hour after the completion of the final heat of racing on the final day of competition. All decisions made by the referee shall be based on the rules of this association. The referee cannot deviate or permit any deviation from the rules. All decisions must be fair and impartial. If and when situations arise that are not fully covered by the rules, the referee may ask for advice from the race committee.

The referee must never become belligerent, boisterous, or raise his/her voice in a manner that might incite needless trouble. The referee is governed by the same rules as the participants, sponsor, etc., and is subject to discipline or even expulsion as a member of this association should he/she fail to carry out his/her duties as the rules provide. Space does not permit these rules to provide all the duties of the referee. Therefore, this all-important position is to be given much thought and consideration by the individual acting in such a capacity.

- b. **Chief Scorer:** The chief scorer is appointed by the BOD and approved by the referee and race director. The chief scorer shall appoint enough scorers to have two groups, which will score and time the boats on the official score sheets and compile all data necessary for transfer to the official race reports and score sheets. In addition, they will watch for gun jumpers and report their findings to the referee. New and one-day membership forms and fees are to be sent to the USTS Treasurer postmarked no later than 15 days after a race. The chief scorer is responsible for driver registration and verifying current and affiliated club memberships at sign-in..
  - c. **Surveyor:** For all sanctioned races to be approved for records, the course shall be surveyed by a competent and licensed surveyor. The surveyor shall certify that the plat is correct and that the course, during the racing event, was in accordance with said plat. A surveyed course will be buoy line to buoy line. The buoy line will mark the exact course, not the lane of the boats.
  - d. **Tech Inspector:** The tech inspector will be appointed by the respective club, subject to approval by the BOD. The inspector shall be responsible for inspection as outlined under Inspection Procedures and will report his/her findings to the referee on the inspection of motors or boats and other infractions that might come to his/her attention.
  - e. **Corner Judge:** The corner judge will be appointed by the referee to watch for rule infractions on the race course turns, which will be reported to the referee. There will be a corner judge situated at each turn.
  - f. **Race Director:** The race director shall be the chairman of the event and chairman of the race committee.
  - g. **Race Committee:** The race committee will consist of the race director, the chief scorer, the inspector, and the turn judges. The referee will attend any meeting as an advisor with no voting rights.
5. **RACE COURSES:** The length of each lap of a course surveyed for records must be 1 mile or  $\frac{3}{4}$  mile from buoy line to buoy line. The course may be any shape desired to best suit the geography. The number of buoys shall be sufficient to mark the race course. The starting line is to be prominently marked on both ends so that drivers can easily designate where the starting line is located. The starting line must be located as far as possible from the first turning buoy. The host club will use air-filled floatation buoys at least 24 inches in diameter and a contrasting color. The referee, due to unavoidable conditions, may reduce the number of laps to complete the schedule. If it is necessary to make these changes, the drivers will receive points, but records cannot be established.
6. **SPEED TRIALS:** The course must be a straightaway of 1 km. A licensed surveyor must survey the course and a chart for the course must be on file at the USTS office. Two buoys, as well as permanent shore markers, must mark each end of the course. Each end of the course must be situated to give the participant ample space for a flying start to enter the course. Boats must be timed by approved stopwatches or programs with competent times under the supervision of the referee. Signals for the timers must be a direct electric connection such as a telephone or electronic system, which may be a photoelectric cell method or radio. The BOD must approve any other method. The contestant must make two consecutive runs. The two runs, in opposite directions, shall be timed, which will give the speed attained. The time must be taken as the bow of the boat enters and leaves the course. Record runs must be made without aid. The run must be completed in both directions to be official. Pit stops will not be permitted between runs. Boats used for speed trials must meet all specifications of the class of the motor used in making the trial run and must be the same type used in closed-course races for that class. The driver must be a member of USTS.
7. **OFFICIAL USTS RECORDS:** Official USTS surveyed records will be awarded for the fastest competition speed. To be official, all records must be set on a 1-mile or  $\frac{3}{4}$  mile closed course. To establish a record, all classes shall run four laps (4 miles or 3 miles). Records will be awarded only if the speed is  $\frac{1}{4}$  of a mile an hour (0.25) faster than the existing record. Records will be awarded after the BOD has been assured all rules are complied with.
- a. Records cannot be established by a driver jumping the gun.
  - b. The timer will start when the starting clock hits zero.
8. **USTS COURSE RECORDS:** Official USTS course records will be site-specific records on race courses that are run each year. The race course will be set by GPS points each year. The courses may vary in length and shape but must remain the same for each site every year. Four laps must be completed to set a record. Records will be awarded to the fastest time and will not have to be broken by a percentage of the existing record. The race course and records may not be protested.
- a. Records cannot be established by a driver jumping the gun.
  - b. The timer will start when the starting clock hits zero.
9. **BOATS:** The definitions of outboard boat designs are:
- a. Hydroplanes are defined as any boat having a multiple surface planning area and which cannot qualify as a runabout.

- b. Runabouts are defined as displacement hulls where the bottom shall have no steps or breaks in the longitudinal continuity. No concave greater than 1/16" will be allowed in the width of the bottom of the boat parallel to the planning surface. No design that uses a tunnel effect is allowed. The side of the boat must form a continuous contour from a single stem to the transom with no concave greater than ¼". Trim tabs that are adjustable by the driver while underway are not allowed. Rub rails or lifting handles are allowed provided they are attached to the outside of the boat, and they do not exceed 1" in width, 1 ½" in depth or 36" in length from the transom forward. The deck is not allowed to protrude beyond the side of the boat. Turning fin brackets may not protrude outside the chine of the boat by more than one (1) inch.
  - c. All fin brackets on both hydros and runabouts must be attached to the hull with a minimum of four (4) thru bolts.
10. **REGISTRATION AND AGE REQUIREMENTS:** To enter and register a boat and motor to participate in any USTS sanctioned event, an individual must be a member of the USTS, complete the entire registration form, and sign the liability release form. If the participant is under the age of 18, the parents at each race must sign the application.

**Minimum age requirements:**

a.	KPro	9-18 years old
b.	125cc	14 years old
c.	175cc & 250cc	16 years old
d.	350cc Runabout, 1100cc Runabout Deck Rider	16 years old
e.	350cc Hydro to 1100cc Hydro, 500cc Runabout to 1100cc Runabout	18 years old

- f. KPRO participants aged 9 until their 10<sup>th</sup> birthday shall be required to install a 0.560 restrictor between the carburetor and the intake. 10-year-old participants until their 11 birthday shall be required to install a 0.650 restrictor plate between the carburetor and the intake. Participants ages 9-11 are required to have a white cross on their helmet. Engine height and all other Tech Rules would remain the same. All "Restricted Drivers" shall be scored after the leader has completed the race. ALL KPRO DRIVERS AND THEIR PARENTS SHALL BE REQUIRED TO ATTEND THE DRIVERS MEETING.
  - g. **A 13-year-old driver who meets all requirements may apply for a waiver to move up to the 125ccR class early. The full list of requirements and waiver application are available from any Race Director.**
11. **BOAT NUMBERING:** All boats are required to have racing numbers affixed on the side of their craft with numbers at least 6 inches in height and 1-inch brush stroke wide in a color of contrast to the main color of the boat. The numbers will be on both sides on a vertical plane. Letters are optional. It should be remembered that the purpose of these numbers is for recognition by officials during an event so that proper prizes and points can be awarded. If the scorers cannot read your number, you will be warned once and will not be scored again until they are legible.
12. **ENTRIES:** Entries must be made on the official USTS entry form, and the provided liability release form signed and filed with the host club before the start of the first event. No entries are to be received after a deadline is set for receiving entries. The race committee, however, can accept any type of correspondence as a substitute until such time a driver can sign an official entry. Drivers under the influence of alcoholic beverages, including beer and hallucinogenic drugs, and any other substance that would impair their mental or physical abilities or even the odor of intoxicants on his/her breath, will not be permitted to enter a racing event. Any driver found guilty of operating a racing boat under such influence, either testing or in a race will be subject to severe disciplinary measures. No driver, official, or member of this association will be permitted to, or allow his/her family or crew to partake of alcoholic beverages, including beer and hallucinogenic drugs, and any other substances that would impair their mental or physical abilities in the pit area or on the judges stand before or during a racing event. Before is to be interpreted as sun-up on race day. During is to be interpreted as the period the race is actually in progress and up to 1/2 hour after the last heat of the day. Referees will not accept any protest either written or oral, from any driver under the influence of alcoholic beverages or mind-altering drugs. Any such driver attempting to deliver a protest shall be subject to severe disciplinary action. The driver is responsible for the actions of his/her crew and for family in the pit area. The penalties for the above will be found elsewhere in these rules under "Penalties for Disqualifications."
- a. A host club can elect to set a time limit for accepting entries or it may refuse, or set a penalty fee for late entries received after a specific time and date.
  - b. Motors and/or boats may be changed between heats, but not both, provided proper entry is made. The race director shall not be required to delay the start of the heat to permit motor changes, except where an additional entry is needed to make an official race. Due to an accident or collision, another boat or motor, but not both, may replace the damaged boat or motor, if the referee has been notified.
  - c. Any racing member may drive a boat and or motor of another member, provided their name and racing number are properly entered on the entry form.
  - d. The number of boats starting in any heat of closed course racing shall not exceed twelve (12) unless deemed safe by the referee. If in any event, there is more than the maximum allowable number of boats ready to run at the time of registration, the entries shall be divided into equal groups up to the maximum allowable number or less, and run in separate elimination heats. A referee may, in the interest of safety, reduce the number of boats starting in any race. The referee

may finish a race in one lap if insufficient boats start to make up the required number needed for the final heat. The only exception to the referee being allowed to run only one lap is elimination heats at championship events. Elimination heats will run the required number of laps if another elimination heat has already been run.

- e. Sponsors may, if they desire, schedule special event classes of racing where the boats and or motors do not comply with the association rules. All participants must be USTS racing members and may enter the class at the sponsor's option; however, the association rules will apply to the drivers entering said class.
- f. The host club, if it desires, may change an entry fee. Entry fees are required to be specified on the race sanction.

13. **LIABILITY:** The USTS assumes no responsibility for injuries or occurrences, which results before, after, or during a race.

14. **DRIVERS MEETING:** A driver's meeting must be held before the start of the first heat of the program. At the drivers meeting, the referee can make any special announcements to the drivers about the race, and permit drivers to ask questions concerning the race. It is mandatory for all drivers to attend the driver's meeting unless excused by the referee. Those not attending the driver's meeting are subject to disqualification at the referee's discretion.

15. **DRIVERS' REPRESENTATIVE:** At the driver's meeting, two driver representatives, whose job it is to represent the race entrants at the judge's stand, will be selected by the race director. All protests, injuries, or other communications from drivers, crew, family, or friends must be directed through the selected representatives and they alone will approach the race director. Violation of any part of this rule will result in immediate disciplinary action by the referee. Disciplinary action for violation of this rule shall include disqualification, fine, or both.

16. **FLAG SIGNALS:** The flags to be used by the flagman during the race shall be as follows:

Red Flag	STOP racing, and return safely to the pits, the course is closed
Green Flag	Course is open
Yellow Flag w/Blue Stripe	Designates caution on the course due to debris, obstruction, or boat stalled on the race course
White Flag	Designates the last lap and the last 60 seconds before the start
Checkered Flag	Designates finish of the race

- a. During a heat of racing, should a driver enter the water for any reason an automatic red flag will be displayed, and the race will be stopped. He/she shall have 10 seconds from the time of entrance to give the "Okay" or "All Right" signal to the referee on the judge's stand. The "Okay" or "All Right" signal motion occurs when the driver clasps one of the wrists with the other hand over the head. After the driver has given the "Okay" signal, and then decides the signal was in error, the driver shall wave one (1) arm in the air as a distress signal for immediate attention, and the referee will order the red flag to be waved. Should the driver give any other signal (or none at all), other than the Okay signal as defined herein, the heat will be red-flagged upon order of the referee. If the referee believes a driver is injured, or an unsafe situation exists or may exist during a heat of racing, the referee may red flag the heat at his/her discretion. Drivers not honoring the red flag are **DISQUALIFIED** for the day.
  - b. Should a restart of a heat be required, all boats that are responsible for the stoppage of that heat will not be eligible for any restart of that heat. Drivers who commit a driving infraction (other than gun jumping) will not be eligible for any restart of that heat.
  - c. **The LITE-ceiver communication system is mandatory in all classes, Open Cockpit and Capsule, for the use of secondary Red Flag communication between Driver and Judges Stand. The Red Flag will still be used on the Judges Stand and in the Patrol Boats as well.**
17. **STARTING PROCEDURES:** A clock or modified Le Mans start are acceptable starting methods. The starting clock, posted at the start/finish line established by the referee, shall be used for all clock starts. The clock must be clearly visible to all contestants when approaching the start line. The clock shall indicate by seconds the elapsed time of the last minute before the start.

The Starting Line is defined as two buoys placed on either side of the front stretch, to establish the start/finish line. This imaginary line shall extend from the outside buoy to the inside buoy, from points located at the 3 o'clock position on the furthest outside edge of both buoys that are closest to the first turn. The starting line video camera shall be positioned and aimed across these two points.

The sound of the first gun or horn will indicate three minutes before the start of the race. The flagman will display a green flag which will indicate two minutes before the start of the one-minute clock. All class entrants will start their engines, and enter the course to the right. All circles to clean out loaded-up motors must be done in the infield during these first two (2) minutes. No boats, other than those entered in that heat, shall leave the pits, unless specific permission is granted by the referee.

At the beginning of the final minute, the flagman will display the white flag and the clock will begin counting down the final 60

seconds to the start of the race. No other boats may leave the pit area and enter the race course at this time. On the approach to the clock, all boats must round all buoys in the second turn on the driver's left. A 500ft buoy will define the chute. Once the driver enters the chute they must maintain a straight line parallel to the race course. Failure to maintain a straight line will result in disqualification of the offending driver for that heat and all restarts of that heat.

Any boat entering the race course after the one-minute gun or horn will be disqualified for the day. If the engine is started when the gun is fired you are permitted to enter the race course.

The official start shall be the exact instant when the starting clock indicates that the final minute has elapsed and the flagman will drop/wave the white flag to indicate the race has officially started.

A legal start is defined as one in which at least one eligible starter crosses the start line at the exact instant or after the clock goes to zero. If a boat or boats cross the start line before the clock reaches zero, the boat/boats will be disqualified from that heat and no points will be granted. If there is a malfunction with the starting equipment, a hazardous situation, or it was impossible to obtain all of the numbers on the boats violating the start, a restart may be called. At championship events, a camera or video camera must be used as an aid. A video camera is also recommended for all races.

To constitute an official race, three (3) starters must cross the starting line before the lead boat finishes the first lap in at least one heat. The exception is for K Pro.

18. **OVERLAP RULE:** When two boats are cockpit to cockpit, an overlap is established. In a position of an overlap, the following rules shall apply:
  - a. The lead boat has the right of way until the overlap is established.
  - b. The overtaking boat must leave a safe lane.
  - c. The overtaken boat cannot force an overlap after the lead boat has altered its course.
  - d. Any violation of the overlap rule listed above will result in the disqualification of the offending driver for that heat and all restarts of that heat.
19. **BEARING AWAY RULE:** A boat shall not bear out of her course to hinder another boat in passing to the starboard side.
20. **COURSE BUOYS:** All turning buoys shall be passed on the driver's left-hand side unless otherwise indicated and announced at the driver's meeting. Outer course markers will define the boundaries of the race course. Once a driver enters the race course, they must stay within these boundaries for the entire race or they will be disqualified. A driver who fails to turn at a buoy must return immediately, circle to the left, inside the course, and pass the missed buoy on the proper side, keeping clear of the balance of the field in doing so. If a buoy position is altered, damaged, destroyed, or dislodged, the buoy ceases to be a marker and may be disregarded. The guilty party shall be disqualified. Damage must be sufficient to alter the position or cause replacement. The referee shall take into consideration if an offending boat forced an unoffending boat into a buoy which then becomes dislodged or destroyed. In this instance, the offending boat will be disqualified. Fines for destroyed buoys must be announced at the driver's meeting or on the sanction.
21. **PROTESTS:** Any driver may protest the eligibility of another driver and his/her equipment either before, during, or after a race. The protest, however, must be in writing, stating the offense to the referee within ½ hour of the last heat of the race day, and accompanied by a \$100.00 fee. The fee will be returned to the protesting driver if his/her protest is upheld. If the protest is not upheld, the fee will be retained by the USTS. The protest will be acted upon by the USTS BOD.
22. **DISQUALIFICATIONS:** The referee is empowered to file charges, including disqualification and fines, against any driver for violation of any of the association's rules. The disqualification or fine shall be made in writing or orally and the driver may, if he/she so desires, appeal the referee's decision to the BOD. After the BOD has been presented with the facts from both sides, it will make a decision which will be final. The referee must carry out his/her authority to file charges against, disqualify, or fine a driver for a violation of the association rules before leaving the race site. In the case of the referee's intentions to file charges against a driver for a rule infraction, which charges are heard by the BOD, the referee must so advise the driver, verbally or written, of his/her intentions to file these charges within 1/2 hour after the completion of the last heat of racing for that day.

A driver also must inform the referee that he/she intends to appeal the referee's decision within 1/2 hour after the completion of the final heat of racing for that day. Failure of any official of this association to carry out any provision of these rules shall have no bearing whatsoever on the right of a contestant or upon the contestant's duty to obey all rules.

Failure on the part of the officials to carry out their duties, subject them to suspension proceedings, disqualifications, or fines for that particular event and further subjects them to discipline by the BOD of the association. Should it come to the attention of any members of the BOD, that a member is violating a rule or rules, or in the case of an official, failure to carry out his/her duties or acting in an unsportsmanlike manner, that member of the BOD may file charges against, disqualify, place on probation, or suspend said person or persons.

Such probation or suspension is temporary but remains in effect until the accused can be given a hearing by proper authority. Any driver or passenger who participates in a race without proper safety equipment, engine kill switch, or starting a motor with the propeller or propeller nut installed not over water, is subject to disciplinary action, or fines as outlined under

“Penalties Disqualifications.” Charges against drivers, owners, and/or pit crew of this association, for violating the articles, rules, or by-laws of this association, or for conduct unbecoming to a gentleman/lady, or unsportsmanlike conduct, will be subject to disciplinary action as defined herein.

**23. PENALTIES FOR DISQUALIFICATION:** Penalties for disqualification are as follows:

- a. Operating a race boat, warming it up, testing, or actively participating in a race without following proper safety rules or the use of safety equipment shall subject the driver to disqualification for that day’s event and a fine of \$100.00 for each offense. The referee may impose one or both of these penalties. However, it is up to the discretion of the referee to decide which penalty or penalties he/she desires to impose. If a cash fine is imposed the money shall be paid into the treasury of the USTS. The referee may ignore this rule if the driver loses any of his/her equipment after leaving the pits.
- b. The referee must disqualify and impose a fine on any driver or official for the day’s event, if that person is found to be under the influence of alcoholic beverages, including beer and hallucinogenic drugs, and any other substances that would impair their mental or physical abilities.

**24. PRIZES:** It shall be the duty of the host club to include in the race circular any proposed prizes. The host club has discretion as to how the prizes are distributed.

- a. Prizes and points shall be awarded to the driver of the boat and not the owner. No prizes or points shall be awarded for a protested event until all protests that might affect the prizes and points have been decided.
- b. Any driver awarded a prize through error, or if in the opinion of the referee is found to have violated the U.S. Title Series rules, then the referee shall demand in writing by registered mail, or by email that the contestant involved must return the prize(s). Refusal of any contestant to comply with the referee’s request shall result in disciplinary action against the driver.

**25. SCORING POINTS:** The following tables of points will be used for the national high point scoring in closed-course racing:

Order of Finish	Points per Heat
First	400
Second	300
Third	225
Fourth	169
Fifth	127
Sixth	95
Seventh	71
Eighth	53
Ninth	40
Tenth	30
Eleventh	22
Twelfth	17
Thirteenth	13
Fourteenth	10
Fifteenth	7
Sixteenth	5
Seventeenth	4
Eighteenth	3
Nineteenth	2
Twentieth	1

- a. At a championship race, 1 ½ the normal points will be awarded. A driver will receive no points in a heat if he/she withdraws from the course or fails to finish. A driver officially finishes a race when he/she does so without outside aid and within three (3) minutes of the lead boat finishing the race.  
 In case two or more boats have scored the same number of points, thus establishing a tie, the 1<sup>st</sup> place winner and/or other places will be determined in this order:
  - i. The driver who has no or the fewest TNT (Time Not Taken) heats. When a boat doesn’t finish a race on the same lap as the leader a TNT is recorded for that boat.
  - ii. In the case of two or more boats are tied on both points and TNT’s, the one that has lowest total elapsed time for heats ran.
  - iii. In the case of two or more boats are tied on points, TNT, and total elapsed time. The one who has the fastest heat.
  - iv. In the case of two or more boats are tied on points, TNT, total elapsed time, and fastest heat, all shall be awarded duplicate points. If any cash prize is available for the win, it will be divided equally

among the winners.

- b. A boat running last may be flagged off the course without completing the number of laps required, at the discretion of the referee, and said driver shall be given points for the position of finish
- c. High point awards shall be made on the basis accumulated between November 1<sup>st</sup> and October 31<sup>st</sup> inclusive.

## **26. Yellow/Red card rule**

A. The referee, assistant referee, Board of Directors member, Officer of the Association, or Category Chairperson may give a yellow or red card to a member for unsportsmanlike conduct at the race site during the sanction period.

B. For unsportsmanlike conduct on the race course, the referee shall issue a yellow/red card on or before one hour after the finish of the last heat of racing except when the offense occurs in inspection, whereupon the card shall be issued within one hour after the finish of the last heat or within one hour of the alleged occurrence, whichever is later.

C. On boat-to-boat contact resulting in transport to a hospital, the following procedure shall take place. A decision on whether to issue a red/yellow card shall be allowed up to 72 hours after the incident. Should more time be needed by the referee, the category chairman can grant an additional 3 days from the end of the 72 hours.

D. A yellow or red card may be appealed to the BOD. An appeal is made by filing a written statement with the Referee or Assistant Referee along with a \$500 filing fee. In the event an appeal is filed, any penalties shall abate until the appeal is decided. The BOD must meet and make a decision on the appeal within 24 hours of the filing of appeal.

E. Additionally, up to two yellow cards can be given at one time for dangerous driving, and a red card can be given for extremely dangerous driving.

F. All cards will remain valid through the four events (entire week/weekend) in which the driver competes following the date on which the last card was delivered. If there are no cards given during those four events, all cards expire.

G. A driver who has a valid red card or three valid yellow cards will lose the right to take part in the next USTS competition event (full weekend) in which he would reasonably compete, and his next championship (divisional or national championship) or race series event. Then all existing cards are removed.

H. All cards must be reported to the USTS BOD within three days of delivery.

I. If a driver receives a third valid yellow card or a red card and is suspended from participation, the BOD will notify the Chief Referee.

J. Cards and penalties in effect extend into the following season.

K. The USTS and APBA have an agreement that any yellow/red cards issued by either organization will be upheld by the other organization.



## Safety Rules and Regulations

Racing is an inherently dangerous sport and each competitor assumes the risk when he/she participates in an event. While everyone involved, drivers, owners, crew members, officials, promoters, and the sanctioning body – can take, and have taken, measures to reduce the risk of serious injury, the risk cannot be eliminated and in fact will always be present.

Participants are solely and directly responsible for the safety of their race craft and racing equipment and are obligated to perform their duties whether as an owner, driver, or crewmember in a manner designated to minimize, to the utmost degree possible, the risk of injury to themselves and others. Neither the USTS, the promoter, nor the conducting club can or will be responsible for the adequacy of a participant's race craft and racing equipment.

During a sanctioned event, all spectators are to be kept out of the water while the race boats are in competition or testing.

1. **INSPECTION PROCEDURES:** Mandatory boat, motor, and equipment inspection shall take place at, or before
2. the first USTS sanction event of the season.
  - a. First event of the season is to be construed to mean the first race of the season a boat and driver has or will be entered in.
  - b. It will be conducted by the inspector, or a member or members of his/her committee.

All boats passing inspection shall have an official USTS safety decal (furnished by USTS national office) applied to the dashboard of the boat.
  - c. The inspector should follow the following procedure when a defect is found:
    - i. Point out the defect to the driver.
    - ii. If it is classified as a minor, defect the driver shall have time to correct it.
    - iii. If the defect is not corrected by the next USTS sanction event in which it is entered, the defective boat or engine will not be permitted to participate.
  - d. Damaged boat or boats must be re-inspected before they are allowed back on the race course.
  - e. If the inspector disqualifies any boat, motor, or equipment from any event for safety-related violations, he/she will report the disqualification in writing, listing the safety-related violations to the USTS national office for review by the BOD.
3. **BOAT INSPECTION:** All boats will be checked for overall soundness.
  - a. Rotten wood in any areas, especially those areas of high stress, running surfaces, and transoms will not be permitted to participate.
  - b. Boats with plastic, polycarbonate or fiberglass cowlings, or windscreens/deflectors will have exposed edges covered with a protective molding.
4. **STEERING AND HARDWARE INSPECTION:** All components of the steering system, including the steering wheel, steering cables, clamps/ tie downs, pulleys, and all other related hardware will be inspected, to ensure that they are in good working order, and are properly secured so that they will not come loose during severe stress.
  - a. Check all cables for soundness and wear.
  - b. Make certain that securing devices (nuts and bolts) are of good quality.

- c. The nuts of the steering bar shall be self-locking, or double nut for safety. Any securing device that is air craft quality, safety wire is acceptable.
- d. The USTS strongly recommends the use of a steering damper.

5. **THROTTLE AND CARBURET/ON INSPECTION:**

- a. Inspect to see that the throttle is properly installed, adjusted for closing, and that it does not bind when operated.
- b. Spray shields on engines are mandatory and may not interfere with the throttle operation. Rear cowlings are an acceptable spray shield.
- c. All carburetors must have full butterflies and guillotine-type carburetors must fully close and shut off the engine.

6. **LANYARD SWITCHES:** All open boats in USTS must be equipped with a lanyard-type kill switch attached by a line to the driver's body or lifejacket. When the driver is thrown from the boat, the switch will activate and render the ignition system of the engine inoperable.

- a. The length of the lanyard or line, when extended, shall not touch the transom.
- b. The switch itself must be of high quality and workable under all conditions in the opinion of the inspector.

7. **PERSONAL SAFETY EQUIPMENT:** It is to be understood that it is the responsibility of the driver to ensure that his/her safety equipment is up to current safety standards and in proper working condition. It is also the driver's responsibility to ensure that he/she is comfortable with his/her equipment, the race course, and club safety procedures before entering a competition.

- a. Helmets shall meet minimum rating specifications for the certifications listed in the chart below. Ratings must be no greater than 12 years from rated date code (i.e., SNELL2015 rating good through the beginning of the 2027 season);

Snell Foundation Specifications	SFI Specifications	ECE	FIA
M 2015	24.1 (2015)	22-06	
SA 2015	31.1 (2015)		
K 2015	41.1 (2015)		

- b. Helmets must be in good working order free of any cracks, defective straps, buckles, loose padding, or broken face shields.
  - i. Construction helmets, football helmets and all others fitting into this category will not be allowed.
  - ii. Helmets must be bright orange, red, yellow, or safety yellow, bright enough to be visible while in the water. The upper fifty percent (50%) of the helmet must be a single color.

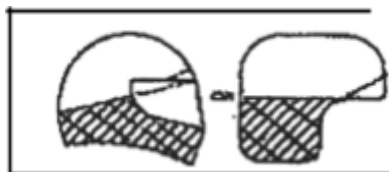

- iii. It is recommended that you purchase a helmet with the correct color manufactured in it. If you plan on painting your helmet, follow the manufacturer's specifications. Caution, some helmets cannot be painted.
- iv. Any driver or passenger who operates or rides in a race boat, either testing or participating in a race without a racing-type helmet worn properly, is subject to disqualification and/or disciplinary action.

- v. Drivers on the race course may remove their helmets only after completion of the heat. Should another heat start before being towed, the helmet will be replaced. Helmets will not be required if the driver is in a rescue or patrol boat.
  - vi. Mounting of GoPro cameras or any similar device to the helmet is prohibited.
- c. **Helmets of Rookie Drivers.** A first year driver's helmet will be affixed with a high-visibility large "X" to let veteran drivers know on the race course, that the wearer of such a helmet may not be experienced in the operation of the race boat.
- i. The "X" may be taped on the helmet but must be highly visible.
  - ii. The "X" on a rookie's helmet may be removed after an inspector and one other race official (i.e. referee), agree that said rookie driver is proficient in the safety rules and regulations of USTS. It is recommended that a rookie spend some time on the judge's stand.
- d. **Life jackets must be designed for boat racing.** An approved racing life jacket must be worn. Parachute jackets are not allowed. All buckles, fasteners, straps, and clevises must be fastened and used as intended.
- i. Gentex or Kapok life jackets are not permitted.
  - ii. Pleasure craft and water skier life jackets are not permitted.
  - iii. Life jackets must be free of tears, loose seams, defective buckles, straps or pads.
  - iv. Impact material for rib protection is required. It can be worn separately or incorporated into the jacket. In addition, there cannot be any voids or gaps in coverage of the impact material, with the exception of the zipper. If the life jacket has any voids or gaps in coverage of the impact material in the rib area, then a supplemental impact material must be worn either under or over the jacket. Any rib protection device or impact material added to the life jacket will be acceptable.
  - v. Recommend that life jackets be returned to the manufacturer every 5 years for recertification.
- e. **Protective clothing** is required wear by all drivers in open boats. Even though protective clothing is mandatory it will not prevent injury in all incidents.
- i. It is required that drivers wear approved cut-resistant (i.e. Kevlar, Spectra, or Cordura) type protective sleeves designed for boat racing.
  - ii. It is required that drivers wear approved cut-resistant pants.
  - iii. Drivers must wear shatterproof eye protection, such as a shatterproof face shield and/or shatterproof safety glasses, etc.
  - iv. Drivers must wear closed footwear with protective soles. Anyone in the hot pit area is required to wear closed footwear with protective soles. (Launching or retrieving boats)
  - v. Any driver or passenger who operates or rides in a race boat, either testing or participating in a race without wearing protective clothing as outlined, is subject to disqualification or disciplinary action.
  - vi. USTS recommends the wearing of neck restraints.
8. **PICK-UP BOATS:** Pick-up boats shall have flags in them, the same as the judge's stand except the checkered flags, to advise the drivers as quickly as possible to changing conditions on the race course. Each pick-up boat will be occupied by a driver with US Coast Guard approved P.F.D.s onboard. Whenever possible, EMT's should also be stationed on the pick-up boat.
- a. Each club sponsoring a USTS-sanctioned race shall have a backboard or basket, an EMT, and a diver in the rescue boat.
  - b. Pick-up boats should be placed inside the race course.
  - c. Each pick-up boat must have a two-way radio and be in contact with the judge's stand at all times.
  - d. There shall be two divers on the race course when capsule boats are on the water.
9. **AMBULANCE:** No race boat will be allowed on the water without a properly manned ambulance on the scene or proper medical personnel with transport available who are skilled in BLS or ALS procedures.

10. **TEAM TRAILER SAFETY:** Every team trailer must have a class BC or ABC type fire extinguisher in good working order and it is recommended that each trailer have a first aid kit. It would be of great value to have several members from each club take a course in emergency first aid.
11. **SAFELY STARTING ENGINES:** No person may start an engine on the bank with a propeller, propeller nut, shear pin, or cotter pin on it. When these devices are affixed to the engine, the engine may only be started in or over the water. Violators are subject to disqualification for one day. When starting a boat to enter a race, then and only then, are you allowed to point the propeller toward the bank. When a boat is in the pits with the propeller installed, the propeller should be covered.
12. **PADDLE IN THE BOAT:** Drivers in open boats are required to carry and use a paddle. The paddle must be painted fluorescent yellow or orange. Drivers are required to try and paddle off the race course. In the event that they don't make an effort, they will be disqualified for the remainder of the heats for that class.
13. **RED FLAG PROCEDURE:** If a driver goes into the water a red flag shall be displayed during a race Drivers are to acknowledge this flag and return to the pit area quickly and safely.
14. **RAISED HAND PROCEDURE:** When a driver is exiting a race for any reason (i.e. mechanical problems, etc.), he/she should raise a hand in the air to let the other drivers know that he/she is exiting the race course. When a driver sees a red flag displayed he/she should raise a hand in the air to assist the other drivers in recognizing that a red flag situation exists. Drivers should exit the course quickly and safely.
15. **UNSAFE BOAT WHILE UNDER POWER:** Should a USTS official notice that a driver cannot properly control his/her boat at all times while on the race course, they may require the driver to withdraw the entry and state the reason to the driver why they requested his/her withdrawal. Should the driver refuse to withdraw the entry after proper explanation, the referee may refuse to allow entry to participate.
16. **HYDROPLANE HULLS:**
  - a. All hydroplane hulls built after 6/1/2013 in classes 125, 175, 250, 350, must have reinforced side protection as shown in the sketches and rounded pickles.
  - b. All dimensions are minimum unless stated. Measurements taken from inside of hull from solid floor on which the driver lays or kneels (no cushions). Reduction to the front side panel is permitted for vision or to have a vision panel installed.
  - c. On kneelers, the amount of cut out to keep stabilization is as per drawings and no reduction at front.
  - d. Cockpit coaming sides shall be made of wood/Kevlar, wood/Kevlar/carbon, or carbon/Kevlar/foam core/glass composition. The Kevlar composition layers add up to a minimum of 340 gram. (10oz.). The Kevlar (and carbon, if used) shall be sandwiched between two or more layers of marine plywood and provide a minimum thickness of 9mm. All composite coaming construction shall have a minimum 9mm thickness. An inspection area shall be provided in the cockpit side to determine that the required materials have been used. It is recommended that this area be a set of concentric circles starting with approximately a 25mm diameter, and reducing in diameter as each layer of the construction lay-up is exposed.
  - e. All hydroplane hulls with pickle forks must have sponson leading edges of a blunt surface that is a minimum of 25mm radius in one direction. The minimum thickness is as shown in the drawing. If extensions of the pickle forks are used, it must have deformable pickle forms for a minimum length to give an exposed blunt surface when removed that is a minimum of 25mm radius in one direction.
  - f. Sponsons on hydroplanes shall not exceed 60% of the hull length.
  - g. Radio communication between a driver and a spotter is not permitted in open cockpit boats.

~~h. LITE receiver communication lights are legal and recommended. Moved Above~~

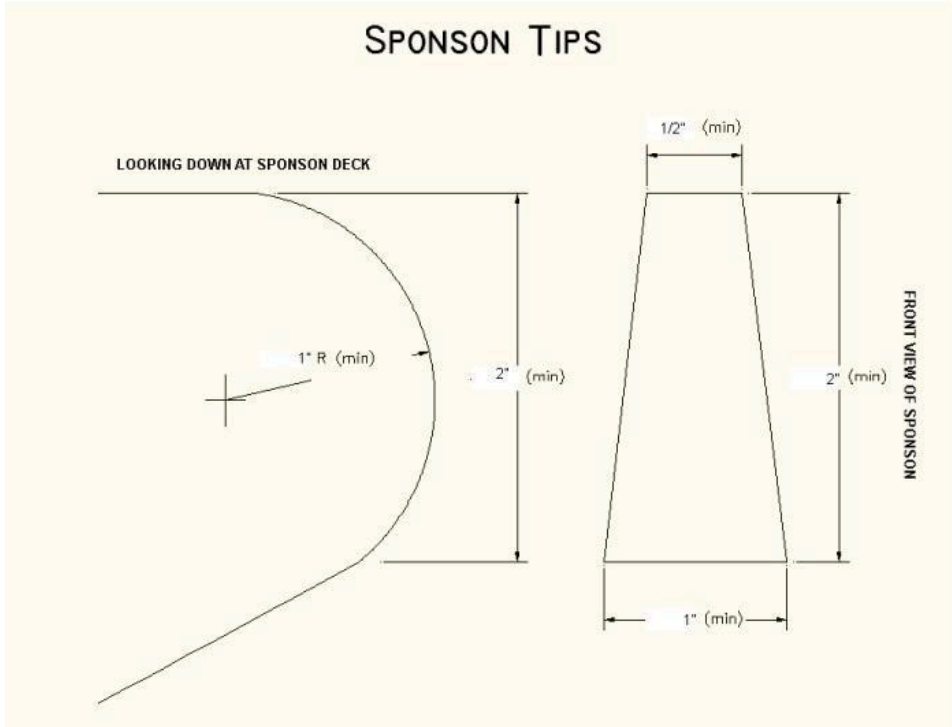
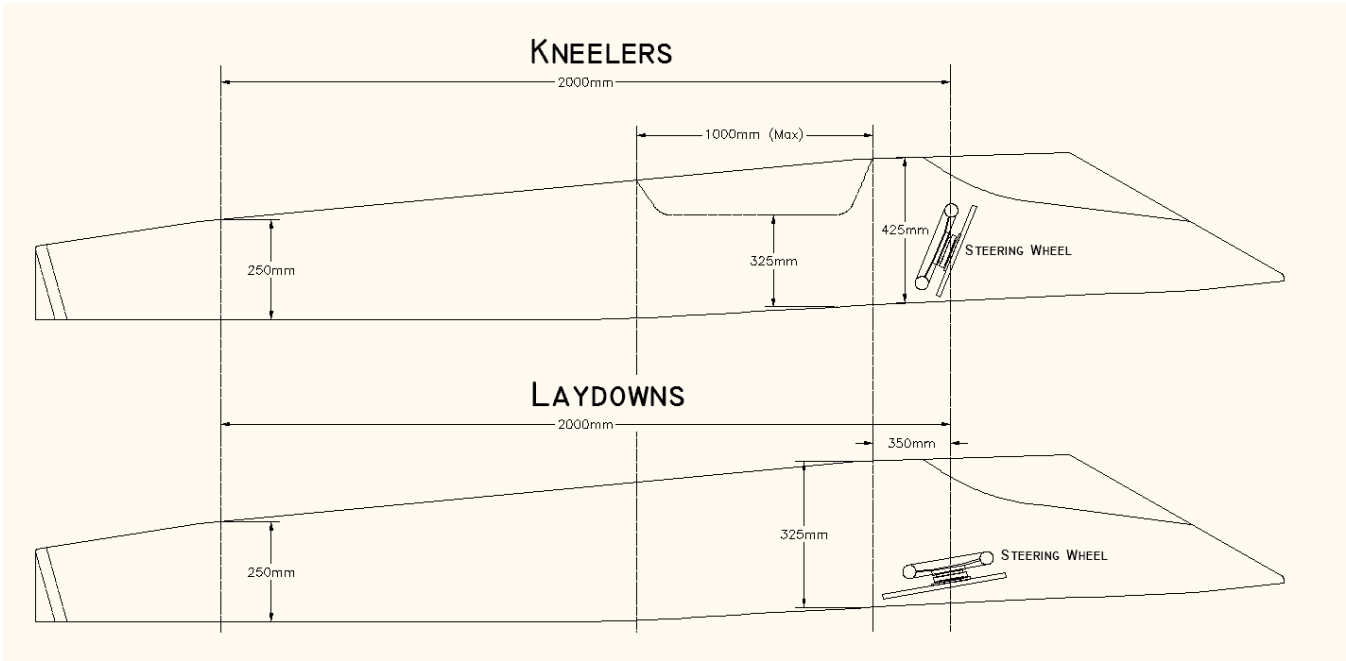

**17. CAPSULE PROCEDURES:**

- a. It is not permissible to cut through the infield while milling until the last 60 seconds before the starts.
- b. If a capsule boat stops on the race course, they are required to open their canopy to signal they are ok to the judge's stand.

**18. CAPSULE TRAINING: All capsule drivers must obtain a capsule safety training certificate every three (3) years.**

Training shall consist of:

1. Demonstrate proficiency in the use of air supply system which the driver carries on board.
2. Demonstrate proficiency in extricating oneself from a strapped in position while submerged.
3. A certificate will be issued to the driver indicating the date of training.
4. The chief scorer may require the driver to produce the certificate prior to registration.

**19. CAPSULES HULLS:**

- a. All 500, 700, and 1100 hydros must be a capsule design.
- b. Capsule will cover the driver's entire body from the side.
- c. Capsules are to be constructed of carbon fiber and Kevlar on both sides of a core similar to balsa wood a minimum of ½ inch should be used with thicker core recommended.
- d. The minimum of a 5 point harness is required, one over each shoulder, one on each side or the driver's lap, and at least one between the legs attaching to the floor of the capsule.
- e. Large fender washers must be used to obtain the proper support through the capsule layup.
- f. Capsule must cover a reasonable portion of the driver's helmet.
- g. The capsule either placed in the boat or actual construction shall have enough buoyancy to keep the boat buoyant.
- h. There must be a minimum of two (2) inch head clearance above the driver's head when seat belts and helmet are in their intended positions.
- i. There shall be one (1) inch eye bolt attached to the rear of each sponson to allow for righting a capsized boat.
- j. All electric controls, ignition, fuel pumps, etc. shall be controlled by the driver in the cockpit.
- k. All cockpit hoods must be removable by divers from the outside of the boat.
- l. An on-board air supply system of the driver's choice shall be mandatory. All part time air system mouth pieces shall be attached to the driver.
- m. Radio communication between the spotter and the driver shall be mandatory. The spotter must be in position to have full view of the entire race course to be determined by the Race Committee. All radios will be tested at least once a year at the referee's discretion
- n. The use of a lever action quick release harness is required.
- o. Life jackets shall be able to support the driver when they are out of boat following capsizing.
- p. The sponson chine and after plane chines of all capsule hydros shall be painted. They shall be painted a bright yellow, orange, or green. The preferred paint code numbers are DuPont yellow #CAS250, green #CAS315, orange #CAS172 or an equal color by another manufacturer.
- q. Two mirrors, one on each side of the boat, visible from the cockpit shall be required.

~~f. Receiver communication lights are mandatory for all Capsule Boat classes. Moved Above~~

- s. A full-time onboard air system is mandatory for the 500H, 700H, and 1100H utilizing reinforced cockpits. (This rule does not apply to the F45 class that follows the OPC Rules.) The driver's mask must cover the driver's nose and mouth and be designed to be watertight. The mask must be attached in such a way as to prevent its being dislodged or removed inadvertently and must be worn by the driver anytime the boat is under power. An ambient air valve is allowed; an ambient air valve is required when air tank capacity is less than 30 cu. ft. The mask shall be worn by the driver anytime

the boat is under racing or testing conditions. All tanks regardless of size shall be designed for the delivery of breathing air. A quick release pressure sealing coupler shall be used to connect the air supply hose from the tank (first stage regulator) to the driver mask hose (second stage regulator).

The rules in this manual give the operational procedures and technical specifications for USTS competition. Each rule has a "Spirit and Intent." Should there be a grey area, lack of specific instruction, or contradiction, etc. the 'Spirit and Intent' of this manual may be exercised. The exercise of this may result in a penalty determined by the race committee or BOD such as, but not limited to warning, disqualification, or disciplinary action. Should there be a question of legality of equipment or race conduct, competitors should seek approval from the BOD or they will be subject to this clause.



## Technical Rules

### ENGINES

1. One outboard engine may be any reciprocating two or four-cycle engine.
2. Turbochargers or superchargers are prohibited.
3. There shall be no more rotary valves than the number of cylinders.
  - a. Multiple rotary valves may not be interconnected to form a positive displacement device such as a Roots blower.
  - b. Shall not have a peripheral speed of more than twice the engine speed.
4. Tuned intake and exhaust are permitted.
5. Propulsion must be by water-driven propeller.
  - a. Maximum gear case length is 24.25 inches including prop nut.
  - b. Tractor lower units are not legal.
  - c. The propeller shaft to driveshaft angle may not exceed 100 degrees.
6. Engine displacement = bore squared x 0.785 x stroke x number of cylinders.
  - a. To convert cubic inches into cc, multiply by 16.387.

### BOATS

No minimum weights apply.

1. Hydroplanes shall be free of all restrictions with the exception that the sponsons shall not exceed 60% of the hull length.
2. 500cc – 1100cc hydro shall be a capsule/reinforced cockpit.
3. 350cc hydro and below shall be an open cockpit.
4. Any boat that meets the definition of a PRO runabout cannot be raced in hydro classes.

### Runabouts:

1. Defined as displacement hulls where the bottom shall have no steps or breaks in the longitudinal continuity. No concave greater than 1/16" will be allowed in the width of the bottom of the boat parallel to the planning surface.
2. No design that uses a tunnel effect is allowed.
3. The side of the boat must form a continuous contour from a single stem to the transom with no concave greater than ¼".
4. Trim tabs that are adjustable by the driver while underway are not allowed.
5. Rub rails or lifting handles are allowed provided they are attached to the outside of the boat and they do not exceed 1" in width, 1 ½" in depth or 36" in length from the transom forward.
6. The deck is not allowed to protrude beyond the side of the boat.
7. Turning fin brackets may not protrude outside the chine of the boat by more than one (1) inch.

Minimum lengths for runabouts are as follows:

125 R – 11' 6"  
250 and 350 R – 12' 6"  
500, 700, and 1100 R – 13'

### FUEL

**PRO** – the use of oxygen tanks in connection with motors is prohibited; fuels that exist as gases at ambient temperature and pressure such as propane, butane, and nitrous oxide are prohibited.

**K PRO and OSY-400** – gasoline and oil mixture must be used that meets current USTS fuel specification test procedures.

## CLASSES

CLASS	DISPLACEMENT
125 R & H	Single cylinder up to 128.75 cc
175 H	175 cc maximum
250 R & H	Over 175cc up to a maximum of 257.5 cc
350 R & H	Over 257.5 up to a maximum of 350 cc
500 R & H	Over 350cc up to a maximum of 500 cc
700 H	Over 350cc up to a maximum of 710 cc
700 R	Konig/Konny rotary valve engine over 500cc up to a maximum of 710cc and any 2 cylinder reed valve engine up to 500cc
1100 R & H	Over 350cc and including 1133 cc
K PRO H	Evinrude and Johnson 15A
OSY-400	Yamato 80, 102, 202, 302, 321

## OMC 15A Technical Specifications

### Notes

1. It is the intent of the tech committee that the engine is raced as received from the manufacturer, without modification. Production model is 1986 to 1992. Pre-1986 cowlings and steering bracket are allowed.
2. Allowable modifications herein are for either safety or repair purposes. An inspector may compare questionable parts to new parts to assist in making decisions. Use of these rules for an unfair advantage will be grounds for disqualification.
3. The driver shall be responsible for the condition of the engine as raced. For instance, errors on the part of the manufacturer, mechanic or previous owner will not excuse noncompliance with the rules.
4. Height restriction: There shall be an absolute minimum distance of 1 3/4" between the boat bottom and the prop shaft centerline at the aft end. The measurement of this height shall be as raced with the engine turned straight (prop shaft in line with the fore-aft centerline).

Following is a list of restrictions, descriptions, and modifications, which apply to this engine.

1. The engine shall retain its complete factory color and decals (or close to it) including powerhead, the gearcase maybe unpainted and/or polished within the template and specifications.
2. The engine shall be operated with the production upper and lower motor covers installed as originally supplied by the manufacturer. All knobs, grommets and plugs shall remain in place or be taped or filled. However, the water outlets controlled by dimensions 'P' and 'Z' may be filled.
3. The mounting of a fuel tank to the engine or steering bar is not permitted.
4. Any type or make spark plug is permitted.
5. Adjustable "high-speed" carburetor jets are not permitted. Larger or smaller fixed jets are permitted.
6. The addition or removal of material from any moving part is prohibited, including the flywheel.
7. The addition or removal of material from internal engine components or surfaces is prohibited. Internal metal surfaces will retain their original factory finish. Honing of the cylinder bores is permitted. Re-sleeving of the cylinder block is legal. The exhaust passage in the lower unit shall retain its original cast surface finish.
8. Broken parts may be repaired by welding or with the use of plastic compounds, if all contours and dimensions remain as original. The gearcase may be profiled as long as minimum dimensions and templates are met. Broken skegs and cavitation plates may be used provided that the edges of the break or breaks have not been filed or smoothed or otherwise altered, and provided that reasonable time was not available for repair or replacement. One or two weeks will be considered a reasonable amount of time. At championship events, the inspector may rule out the use of broken skegs or cavitation plates.

9. It is permitted to repair stripped threads by tapping oversize or using heli-coils or threaded inserts.
10. It will be permissible to use a thrust bracket of any manufacturer, provided the engine is not altered. The steering bar brackets shall have their S.A.E. grade 5 (or higher) retaining bolts safety wired as supplied by the manufacturer. Alternative is the use of studs and the steering bar brackets must have washers and locking nuts.
11. The carburetor butterfly screw must be furnished by the manufacturer. Other than that screw, and the steering bracket bolts, any make type of nut, bolt, screw, washer, or stud maybe used. Any bearing or seal is allowed as long as it fits original bores without alterations.
12. Only minimal amount (thin film) of sealer may he used on engine gaskets.
13. The intake and exhaust ports are drilled (round) holes. Only the center transfer port and the center exhaust port for each cylinder break through fully into the cylinder bore. All other ports do not fully break through into the cylinder bore. Port openings may have plastic compound added for repair. It is illegal to completely fill and re-drill.
14. The gear case split line screw cavities shall be left as supplied by the manufacturer (i.e. unfilled).
15. The only permitted cylinder block is OMC part number 396780. The part number is cast on the top of the block on the exhaust side. Service number 396010 includes block 396780.
16. Boyesen reeds number 122 and 122R are legal replacement parts. Except for reed thickness, and the shim may he removed, all other specs apply.
17. The only legal flywheels are either OMC part number 583077 or 583913. The part number is cast on the underside of the flywheel.
18. The only legal carburetor assembly is OMC part number 397653, and service carb with 388275 stamped into the top of the carb body. When converting a service carb, a full butterfly, similar to the original must be used, or solder or epoxy the hole closed. It is allowed to weld a cracked flange. Weld penetration maybe machined but no polishing beyond factory finish, nor enlarging.
19. It is permitted to remove the transom cleats, which are located in the transom surface of the stern bracket.
20. The engine must meet the requirements of the OMC inspection template as listed below:
  - OMC part number 568050 for the gear case.
  - OMC part number 568051 for the shape of the combustion chamber.
  - OMC part number 568052 for the height of the ports.
21. It is permissible to use two standard gaskets, OMC part number 318932 between the carburetor and the intake manifold.
22. The only legal transfer port covers are part number 328820 and 333733 and 336637.
23. Inner exhaust plate part number 323497 is legal.
24. Solid motor mounts of any manufacture is legal.
25. OMC/BRP piston and ring manufactured for this year and model engine is permissible. Standard piston (P. N. 332364), 0.010" piston (568523), 0.030 (393852), standard ring (386279) or 0.030" oversize (386288). The 0.030" oversize ring may be used on the 0.010" oversize piston in addition to the 0.030" oversize piston, and may be cut down to fit the cylinder bore for use on the 0.010" oversize piston. Aftermarket GLM piston and rings available as standard and 0.030" are legal. Part numbers standard kit 24410, just rings 23710; 0.030" kit 24430, rings 23730. Wiseco 0.040" piston and rings are legal part number 3136P4.
26. The water pump impeller may be held on the prop shaft by any means.
27. The use of a 12-volt DC electric starter and corresponding flywheel is legal.
28. Because the following parts are no longer available from OMC/BRP, they may be reproduced by any manufacturer.
  - Steering bar brackets (must be steel)
  - Steering bars

Stator plate locking bracket  
 Carb linkages and bowden wire mounts  
 Carb baffle plate  
 Driveshaft

### OMC 15A Specification Chart

CC's	13.5 min.
Venturi	0.875 +/- 0.005
Throat	1.000 +/- 0.005
A	3.480 max.
A1	0.625 +/- 0.010
A2	0.625 +/- 0.025
A3	3.490 max.
C	3.680 max.
C1	0.626 +/- 0.010
C2	0.625 +/- 0.025
G Bore	2.235 max.
K	4.880 +/- 0.015
K1	4.520 +/- 0.025
K2	1.830 +/- 0.020
X	1.086 +/- 0.010
E	3.918 +/- 0.010
F	1.868 +/- 0.010
J	1.760 +/- 0.008
L	3.000 +/- 0.006
M	0.642 +/- 0.014
H	0.256 +/- 0.020
H1	5.000 +/- 0.50
N	1.430 +/- 0.015
N1	1.010 +/- 0.030
N2	0.675 +/- 0.025
Y	1.260 +/- 0.030
U	10.633 +/- 0.050
U1	10.510 +/- 0.050
T	0.280 +/- 0.060
D	0.880 +/- 0.020
D1	0.500 +/- 0.020
Q	11.550 +/- 0.200
Q1	9.100 +/- 0.200
V	18.000 +/- 0.060
R	2.050 min.
S	0.980 min.
W	4.765 +/- 0.020
W1	4.340 +/- 0.100
Ratio	14:19

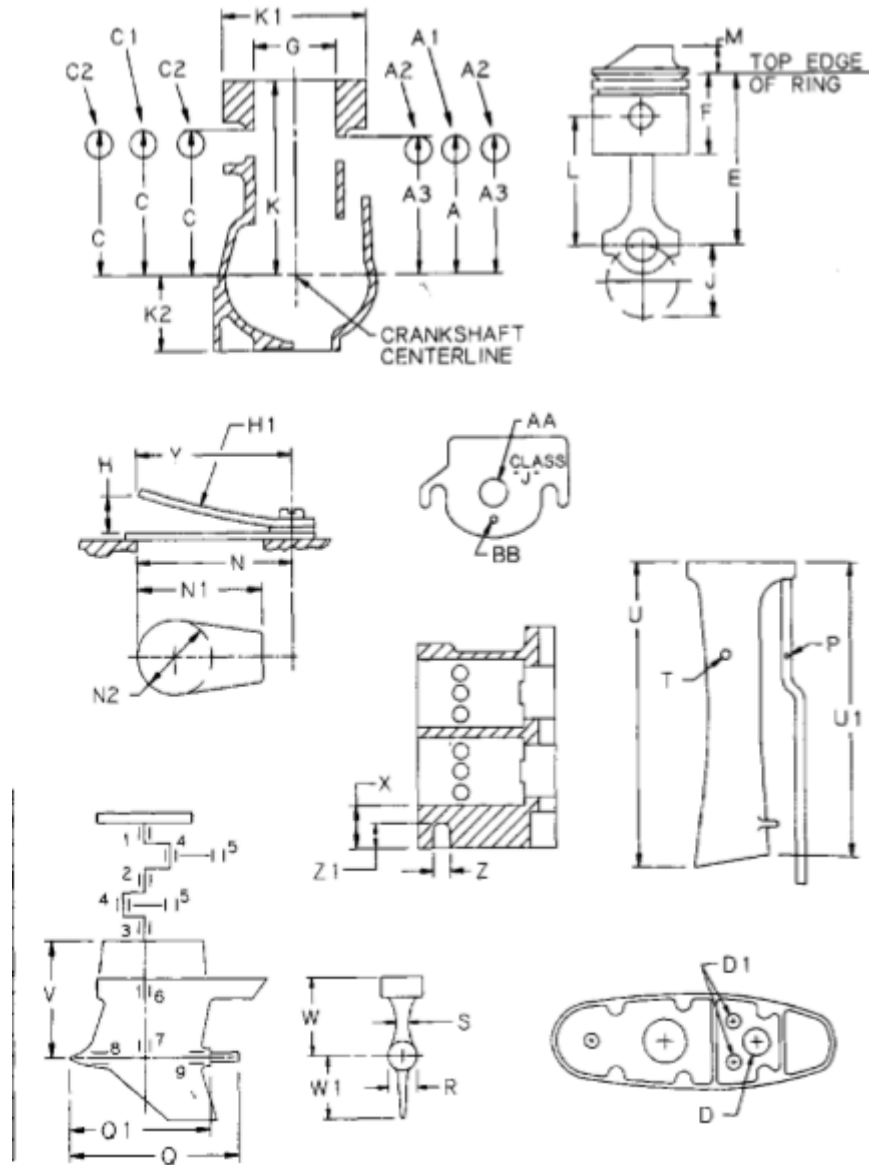

Stainless Steel Reed Thickness

## OSY 400

### Yamato models 80, 102, 202, 302, 321

IT IS THE INTENT OF THE U. S. TITLE SERIES AND THE TECHNICAL COMMITTEE: FOR THE APPROVED YAMATO ENGINES TO BE RACED AS MANUFACTURED. ALLOWABLE MODIFICATIONS LISTED BELOW ARE EITHER FOR SAFETY OR UPDATES TO REPLACEMENT PART(S). BETWEEN THE WRITTEN WORDS AND SPECIFICATIONS SHEETS, THERE ARE NO OTHER ALLOWABLE MODIFICATIONS.

1. The legal engines are models: 80, 102C, 202D, 202E, 302F and 321.
2. It is permissible to use any make of bearings, seals, ignition components, piston rings, steering bar, or prop shaft provided no engine modifications are made to accept them.
3. Except for the carburetor butterfly screw, any type nut, bolt, screw, or washer maybe used.
4. The carburetor butterfly and shaft cannot be thinned or tapered.
5. The spray shield maybe modified to allow access for priming and maybe painted.
6. It is permissible to enlarge the fuel tank or build a new one. A fuel filter maybe used.
7. A fuel pump maybe used but no modification to the carburetor is allowed.
8. It is permissible to drill water drain holes in the ignition castings and top end bearing cap. These holes can be taped and plugged.
9. The ignition timing stator plate maybe locked into place by any means. The timing knob handle maybe cut off.
10. It is allowed to use the 202 magneto on a 102.
11. It is allowed to remount any coil on the 80, 102, 202 magneto engines.
12. Aftermarket roping plate is allowed on the 102, 202 magneto, as long as it meets OEM dimensions.
13. To identify a 101 from a 102, the 102 has an exhaust manifold width of 3 3/16".
14. The latest replacement Carburetor is approved for use on the 102, 202, 302 and 321.
15. It is legal to bore the cylinders one size over standard bore. It is permissible to re-sleeve the block as long as all specifications are met.
16. It is permissible to mill the cylinder head. Minimum cc's must be meet. No changes to the combustion chamber. The squish band maybe re-machined for repair. There must remain a ridge on the 0. D. For the 80: angle 15 + 2 degree, 2.35 + 0.015". For 102, 202, 302, and 321: angle 15 + 2 degree, 2.612 + 0.015".
17. 80's have exhaust manifolds with one and two water outlets. Both are legal.
18. It is permissible to use aftermarket crank pins.
19. It is permissible to use 302/321 pistons in a 102. The ring location pins maybe removed and new ones installed.
20. Any water outlet holes on the bottom of the block cannot be restricted in any way.
21. Any type of thrust bracket maybe used. It is allowed to drill two holes on the upper cavitation plate for mounting a thrust block.
22. The tilt lock and parts can be removed.
23. On the 80 and 102, the exhaust stack maybe repaired by welding and gussets on the outside only. Any attempt to alter the internal configuration is illegal.
24. On the 80 and 102, aftermarket exhaust stacks are legal as long as all dimensions are met. The 80 new style elbow has a minimum 3/16" hole approximately Y2' to the rear and 7/16" above the clamping slot. It may be added to the old style elbow or drilled in the pipe at the top of the clamping slot.
25. The water inlet hole(s) on the exhaust snout, maybe repaired with weld or epoxy. The hole diameter is 0.270 to 0.290". Contours must remain as original.
26. The prop shaft maybe turned down to 9/16" diameter or a new one can be made. In either case only one shear pin hole is allowed. Caution on cut down prop shafts, they usually break.

27. It is permissible to contour and polish the gear case within the specifications.
28. It is permissible to use the 302/321 gear case on a 102 or 202. However a 102 or 202 gear case cannot be used on a 302 or 321.
29. A 302/321 gear case can be identify by the snap ring and metal plate at the rear of the tail cone. Some were made with oil drain and fill screws and some not. You cannot eliminate the .holes or add them.
30. 30) Aftermarket gears for the 80, either helical or straight cut teeth of 14:16 gear ratio is legal.
31. For 102 or 202, helical or straight cut gears are legal in 14: 15 ratio.
32. New style 302 rope plate and trigger unit maybe used, but together as an assembly.
33. For the 80, Wiseco pistons part number 0186m.06046 are legal.
34. Minimum age requirement -14 years

## Yamato 80 Diagrams

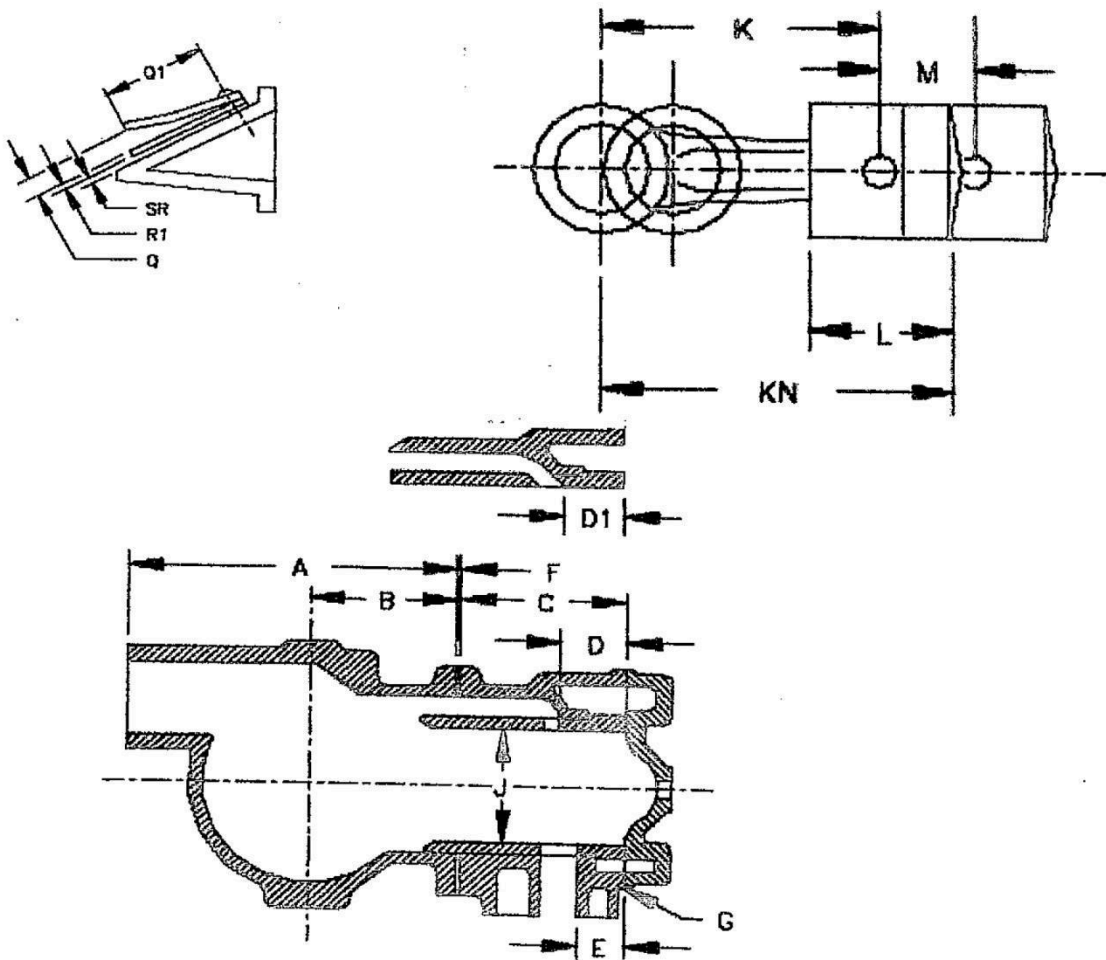

**Yamato 80 Diagrams**

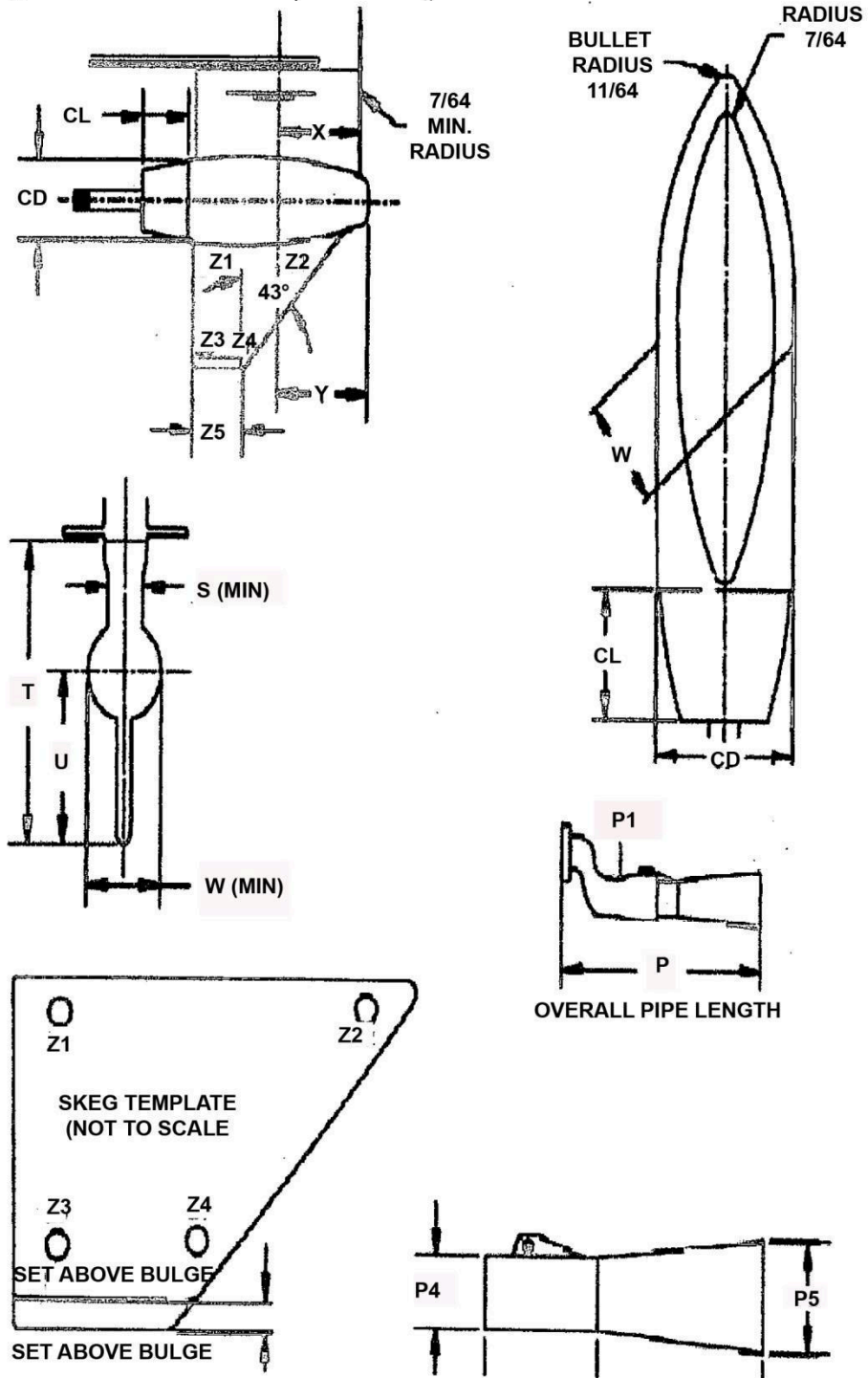

**OSY 400**

Yamato 102, 202, 302, 321 diagrams

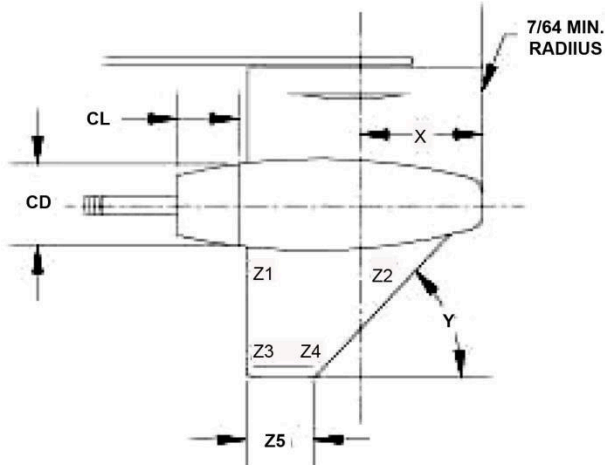

**YAMATO 302**  
**ALTERNATIVE EXHAUST OUTLET CONFIGURATION**  
 (This modification is permissible for all 302 exhaust housings. The water intake tube must be re-plugged at the machined surface to avoid engine damage.)

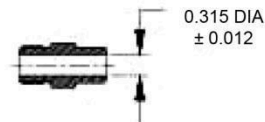
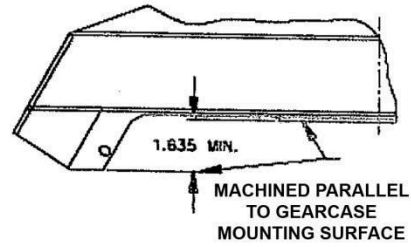

**302 WATER OUTLET**

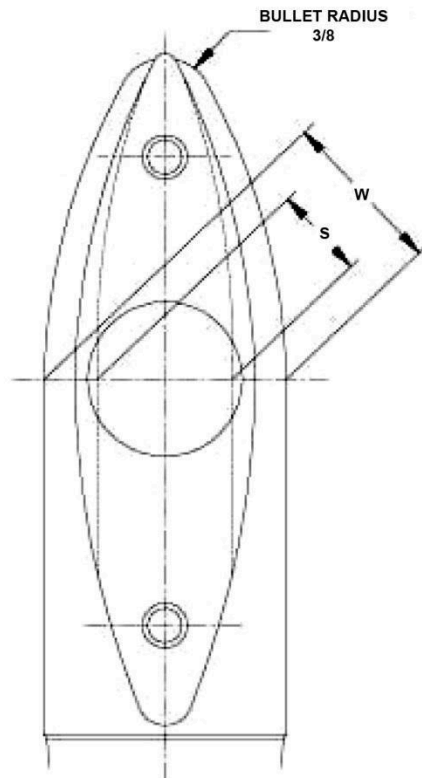
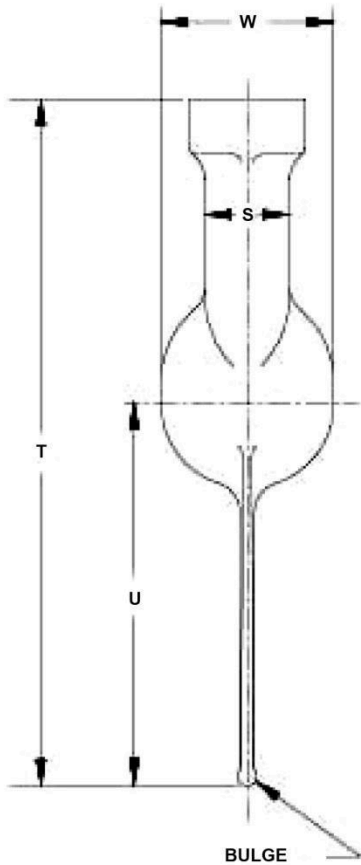

**OSY 400**

*Yamato 102, 202, 302, 321 diagrams (cont.)*

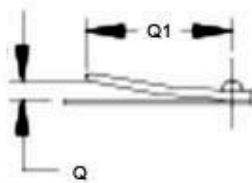
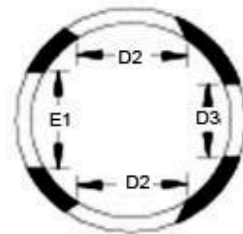
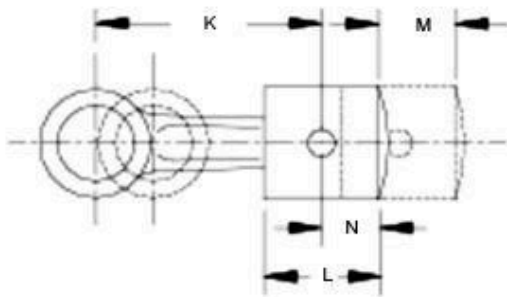
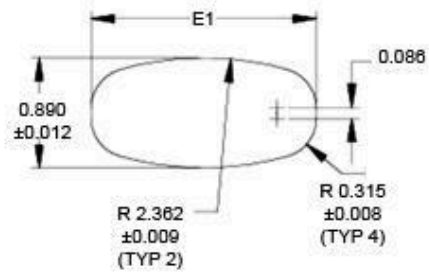
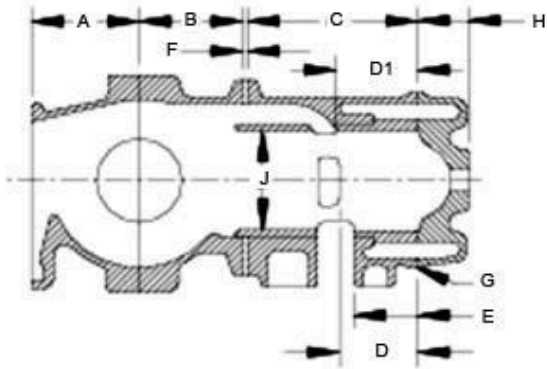

**TUNED EXHAUST STACK (CAST)**

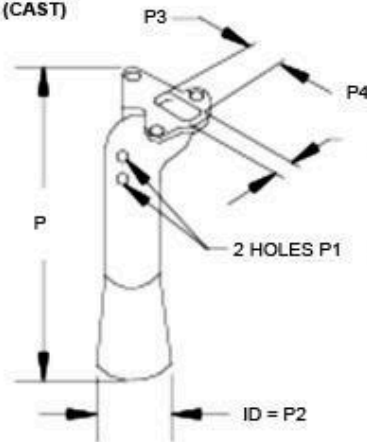

**OSY 400**

Yamato 102, 202, 302, 321 diagrams (cont.)

MODEL	80	102	202/302/321
CC's 14mm 18mm	18 19	25.5 26	25.5 26
CARB - MIKUNI	BV-30	BV-36	BV-36
VENTURI	0.999 - 0.969	1.103 +/- 0.003	1.102 +/- 0.012
GEAR RATIO	14:16	14:15	14:15
A	5.980 - 6.024	2.540 - 2.560	2.827 - 2.843
B	2.752 - 2.760	2.535 - 2.555	2.539 - 2.251
C	3.885 - 3.906	4.094 - 4.114	4.102 - 4.114
D	1.800 - 1.830	1.880 - 1.890	1.890 - 1.913
D1	1.840 - 1.860	1.855 - 1.875	1.772 - 1.827
E	1.420 - 1.460	1.430 - 1.450	1.389 - 1.402
E1 EXHAUST OVAL HEIGHT X WIDTH	\\\\\\\\\\\\\\\\	\\\\\\\\\\\\\\\\	1.811 +/- 0.020 X 0.890 +/- 0.012
F	0.010 - 0.020	0.004 - 0.012	0.004 - 0.012
G	0.020 - 0.040	0.016 - 0.022	0.016 - 0.022
J	2.387 max	2.625 max	2.625 max
K	4.204 - 4.221	4.204 - 4.221	4.204 - 4.221
L	2.322 - 2.404	2.322 - 2.402	2.346 - 2.378
M	2.279 - 2.288	2.286 +/- 0.010	2.276 - 2.291
N	1.291 - 1.307	1.280 - 1.301	1.291 - 1.301
P	10.625 +/- 0.062	11.625 +/- 0.050	10.157 - 10.315
P1	1 @ 0.187" min.	2 @ 0.203 max	2 @ 0.185 - 0.209
P2	\\\\\\\\\\\\\\\\\\\\	2.400 +/- 0.025	2.469 +/- 0.040
P3 MAX	\\\\\\\\\\\\\\\\\\\\	2.180 max	1.772 x 1.575
P4	1.614 +/- 0.050	1.060 max	1.535 - 1.614
P5	2.598 +/- 0.050	\\\\\\\\\\\\\\\\	\\\\\\\\\\\\\\\\
O	18.464 - 18.622	18.464 - 18.622 *	17.283 - 17.402 *
T	8.415 - 8.515	8.415 - 8.515	8.415 - 8.515
S	1.161 min.	1.195 min.	1.195 min.
W	2.204 min.	2.205 min.	2.205 min.
X	2.874 - 3.031	2.980 +/- 0.030	2.980 +/- 0.030
Y	3.267 - 3.425	50°	50°
CD	2.150 min.	2.100 min.	2.115 min.
CL	1.772 max.	1.772 max	1.772 max
Z1	0.185 min.	0.190 min	0.190 min
Z2	0.185 min.	0.190 min	0.190 min
Z3	0.130 min.	0.150 min.	0.150 min.
Z4	0.130 min.	0.150 min.	0.150 min.
Z5	1.969 +/- 0.050	1.949 min.	1.949 min.
Q	0.281 max	0.289 max	0.289 max
Q1	1.350 - 1.420	1.342 - 1.421	1.272 - 1.350
R1	0.010 - 0.014	0.010 - 0.014	0.010 - 0.014
SR shim	0.006 - 0.009	\\\\\\\\\\\\\\\\	\\\\\\\\\\\\\\\\
Reed port opening max	\\\\\\\\\\\\\\\\	0.788 x 1.036	.0512 x 1.142
Flywhel Wt. min.	1279g / 2.86 lbs.	1500g / 3.31 lbs.	1500g / 3.31 lbs.
* Note: 202D is same length as 102.			
Note: The 321 has in the tower housing, an internal exhaust cast baffle. The upper square is 26mm x 26mm or 1.023" x 1.023" with some flashing removed at the entrance. As an as cast surface, there cannot be any tampering to these surfaces.			

## USTS YAMATO APPENDIX



First it is necessary to identify the lowest point of the allowable hole, which is 1.500" below the flat area of the cavitation plate. It is important to ensure that you are measuring outside the radius at the bottom of the exhaust strut. Using a ruler, mark the leading edge of the strut and draw a line parallel to the cavitation plate. This line is the maximum limit of the hole.

### Exhaust Strut

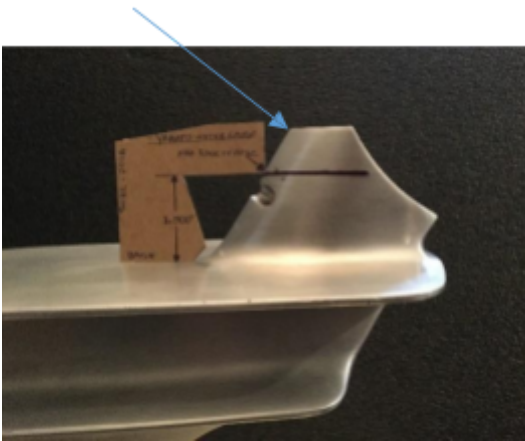

Using a business card, align the bottom edge of the card with the edge of the water inlet hole and the long edge of the card with the leading edge of the exhaust strut. Holding the card with one hand, use a Sharpie to draw a line for the edge of the exhaust strut, leading downward to the cavitation plate. This line represents the angle at which the water inlet hole would be enhanced.

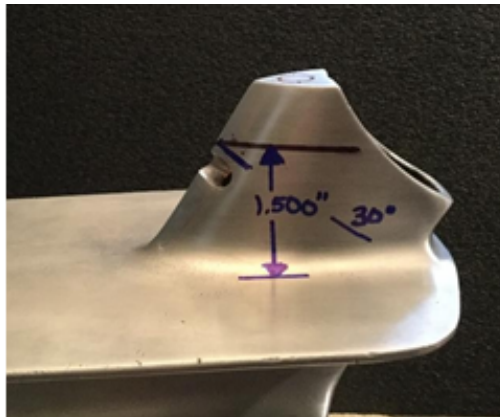
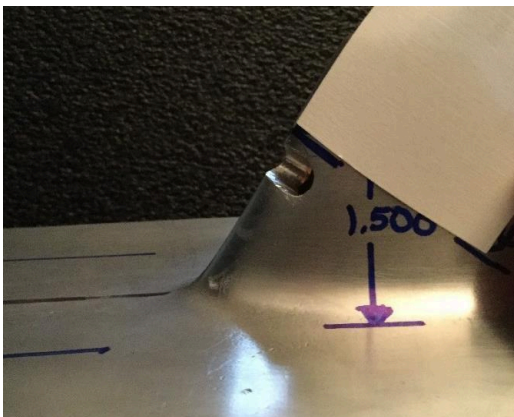

## USTS YAMATO APPENDIX

The file should not go deeper than one-half inch. There should be a straight cut towards the center of the copper water inlet tube. Essentially, the hole is centered on the leading edge of the strut toward the center of the hole in the copper tube. See if the hole goes beyond the leading edge of the strut. It is agreed that 1/8" works. A hole larger than 9/32" or 0.281" is not acceptable. The copper tube should not be entered; only the aluminum surface should have been reamed.

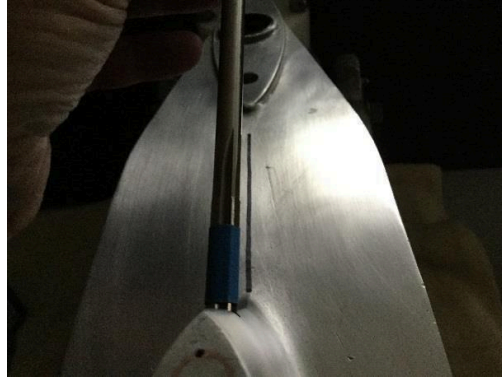
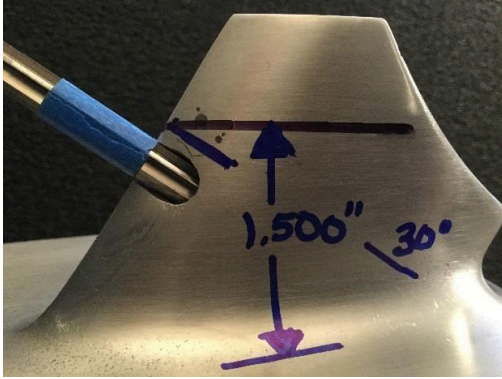

### Port Side

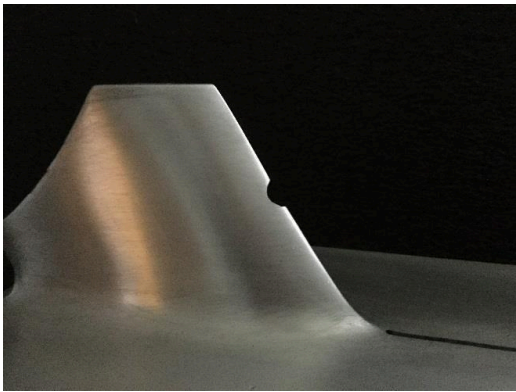

## FUEL OSY-400 and K PRO

Permissible fuel shall consist of gasoline and oil. Gasoline may be automotive, aviation, or racing, either leaded or unleaded varieties, so long as it does not contain power boosting additives such as alcohol, nitrates, or oxygen bearing compounds. Gasohol is not permitted. Oils may be petroleum, synthetic, or a blend of both, and cannot contain power boosting additives. Any driver using illegal fuel will be disqualified.

### FUEL TESTING PROCEDURES

#### *Digatron DT-15 & DT-47 Fuel meter*

The purpose of this test is to measure certain electrical properties of the fuel sample determine if they are within the permissible limits.

Before performing your test, ensure that the fuel meter is in good working order:

1. Sensor Condition - Visually check the sensor and its connecting wire to assure that it has not been physically damaged.
2. Battery Condition - When the meter is on, the words "LO BAT" will appear in the upper left corner of the display if the battery needs to be replaced. Do not use the meter if the "LO BAT" message is displayed, as its readings will not be accurate.

#### **The recommended fuel test procedure is as indicated below:**

1. Turn the meter "ON" and allow it to warm up for at least fifteen (15) minutes before doing any testing. This will allow the internal components to stabilize at their normal operating temperature.
2. Attach the sensor's connecting wire to the meter. Hold the sensor's connecting wire and lower the sensor into the calibration liquid (Cyclohexane - C<sub>6</sub>H<sub>12</sub>) in such a way that the sensor is completely submerged. Take care to assure that the sensor is not in contact with the container. (Container should be plastic - never glass or metal -- with a cover to reduce evaporation or water absorption. This container should be on a plastic or wood base, never metal; it effects the metering.) Gently wiggle the sensor wire to displace any air bubbles which may be trapped between the sensor plates. Using the knob on the front of the meter, adjust the meter until the display reads "- 75" (negative seventy five).
3. Remove the sensor from the calibration liquid, and blow any excess liquid from between the sensor plates. Lower the sensor into the fuel sample just like you did while calibrating the meter. Observe the reading on the meter's display. If the reading is zero (0) or a negative number, the fuel is permitted. If the reading is greater than zero (a positive number), the fuel is not permitted.

The electrical characteristics of gasoline change somewhat with temperature. As such, it is important that the temperature of the fuel sample and the calibration liquid be within 15 degrees of each other.

When a fuel sample is found to be illegal, per the above procedure, it is recommended that the following additional steps be performed:

- A) Clean the sensor with some spray-on brake cleaner and allow to air dry at least 30 seconds.
- B) Re-check the calibration setting (-75) of the meter in Cyclohexane and adjust if necessary.
- C) Allow the fuel sample to stabilize to the same temperature as the Cyclohexane and then repeat the test as described in item 3 above.

During the course of the day, it is recommended and necessary to recheck the calibration setting in Cyclohexane.

### Specific Gravity Testing Instructions

The purpose of this test is to measure the relative density of the fuel sample and determine if it is within the permissible limits.

Two pieces of equipment are required to perform this test:

1. Specific gravity hydrometer(s) which cover the range.
2. A clear glass container which is at least as tall as the hydrometer. A graduated cylinder works well for this purpose.

The recommended fuel testing procedure is as indicated below:

1. Assure that the glass container and hydrometer are clean.
2. Place the glass container on an essentially level surface and fill it with the fuel which is to be tested. The depth of the fuel should be equal to, or greater than, the length of the hydrometer.
3. Carefully insert the hydrometer into the fuel sample with the weighted end facing down. Take care to minimize the contact between the hydrometer and the container.
4. When the hydrometer has reached a stable free float in the fuel sample, read the specific gravity from the scale within the hydrometer. This is done by visually sighting along the upper surface of the fuel and reading where the scale crosses the fuel's surface. Record this reading.
5. Measure the temperature (degree F) of the fuel.
6. The specific gravity characteristics of the fuel (gasoline and oil) change somewhat with temperature. As such, the maximum and minimum permissible specific gravity reading will change as the fuel temperature changes. Below is a listing of the maximum permissible specific gravity readings and their corresponding fuel temperatures. The standard is from 0.690 to 0.760 @ 60°F.

Fuel Temp Degree F	Specific Gravity Reading	
	Min.	Max.
40	0.699	0.769
45	0.696	0.767
50	0.694	0.765
55	0.692	0.762
<b>Standard 60°F</b>	<b>0.690</b>	<b>0.760</b>
65	0.687	0.758
70	0.685	0.755
75	0.683	0.753
80	0.680	0.751
85	0.678	0.748
90	0.676	0.746
95	0.673	0.744
100	0.671	0.741

**Other tests:**

An Inspector may use other tests such as **Water Solubility, Ceric Nitrate Reagent** and/or have a sample sent to a laboratory.